

**Part no.: 53800134**  
**BT840M**  
**Mounting bracket**

Figure can vary

## Contents

- Technical data
- Dimensioned drawings

Part no.: 53800134 – BT840M – Mounting bracket

## Technical data

### Basic data

Application	Mounting on chamfered 90° corner
Suitable for	RSL 400 safety laser scanner

### Mechanical data

Dimension (W x H x L)	84.9 mm x 72 mm x 205.2 mm
Net weight	1,080 g
Housing color	Yellow, RAL 1021
Type of fastening, at system	Through-hole mounting
Type of fastening, at device	Screw type
Mounting device material	Metal

### Classification

eCl@ss 8.0	27279202
eCl@ss 9.0	27273701

## Dimensioned drawings

All dimensions in millimeters

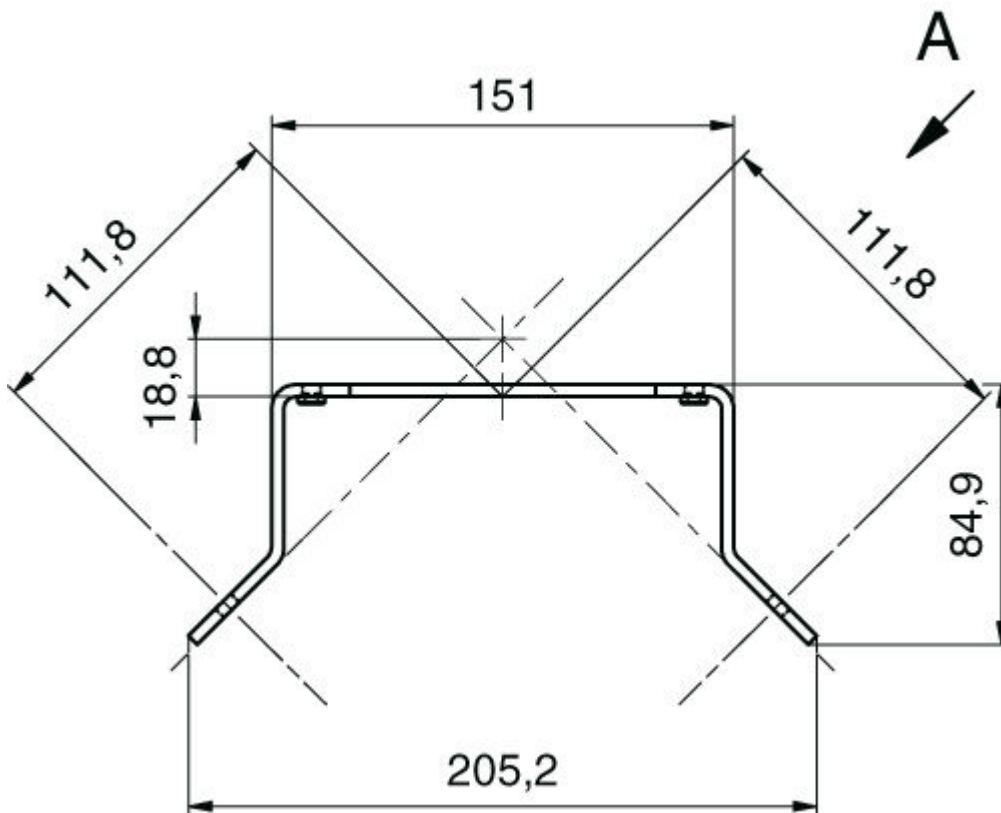

View A

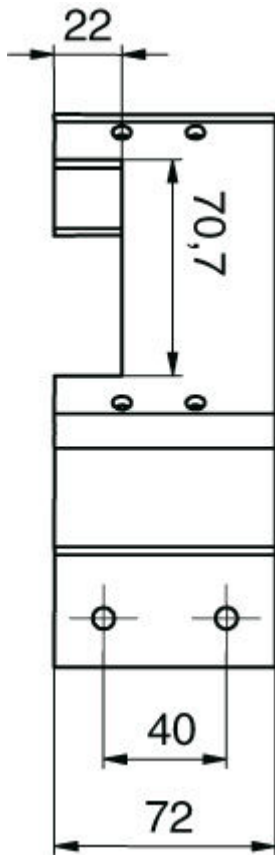

Part no.: 53800134 – BT840M – Mounting bracket

Example: mounting on a chamfered corner

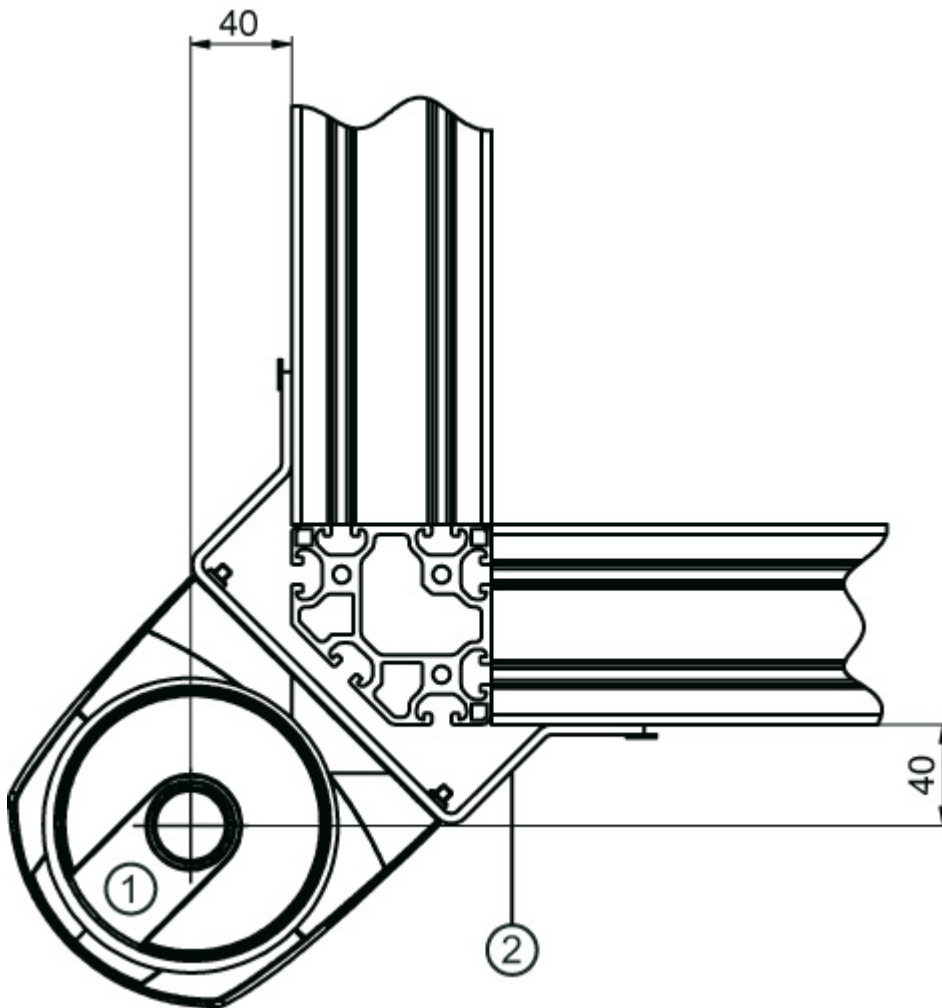

- 1 Safety sensor
- 2 BT840M mounting bracket